



ATECMAA
PACKAGING

CUB·X
ACS AUTO CONTROL SYSTEM

AUTOMATIC CYCLE STRECH-WRAPPING MACHINE

CUB.X

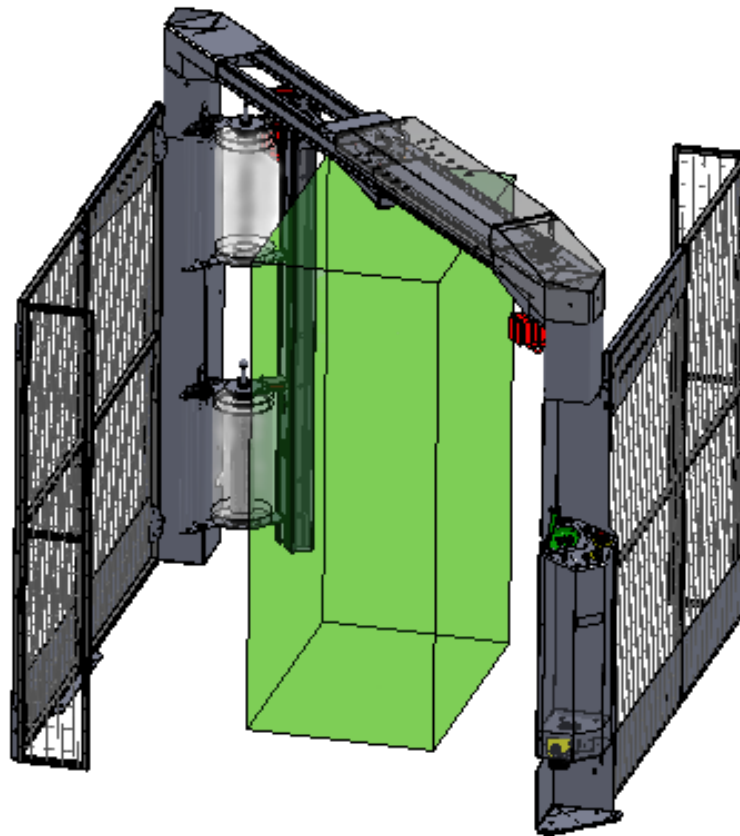

TECHNOLOGIES ET PROCESS D'EMBALLAGE

32, rue de Charette • 28140 TERMINIERS - FRANCE
Tél : 33 (0)2 37 18 58 13 - Fax : 33 (0)2 37 32 11 34 ou 33 (0)2 37 32 14 22
www.rassinouxa.com - Commercial production : clients@rassinouxa.com
Comptabilité : compta.mf@rassinouxa.com - Qualité : qualite@rassinouxa.com

RASSINOX SAS au capital de 2 130 000 Euros—SIRET 353 267 446 00014—APE 2250B—FR 41 353 267 446 CHARTRES
ATECMAA PACKAGING enseigne commerciale de la société RASSINOX SAS—www.atecmaa-packaging.com



TECHNICAL FEATURES:

- Installed power: **1 KW**
- Power: **230 V Single Phase + Earth**
- Manufacture: **IP54**

Overall dimensions:

- Length: **see diagram on page 4**
- Width: **see diagram on page 4**
- Overall height: **see diagram on page 4**
- Weight: **420 kg**

Accepted dimensions of the pallets:

- Length: **1200 mm**
- Width: **800/1000 mm**
- Height: **2100 mm**
- Max.load: **no maximum**

ASSEMBLED PARTS OF THE MACHINE:

- **Rotating arm** folded sheet metal made driven by geared motor with frequency converter with chain drive.

- Variable speed from **6 to 15 rev / minute**
- Indexed stop
- Safety system against arm rotation related risks:



- **Patented ACS (Active control security system) system**
- **Industrial safety system**
- **Industrial mesh panels**
- **Emergency stop on the control panel**

- Foldable** rotating arm (see picture on page 3), taking very few **space: 6,25 m2 – can hold under storage racks**
- Easy relocation** of the machine (see picture page 3) and very compact.

- **Bobbin carriage** driven by geared motor with frequency converter and chain drive.

- Variable speed
- Top / bottom stop detectors
- Cell for automatic detection of the height of the pallet
- Tension strength adjustable by mechanical brake (see picture on page 3)
- Easy loading and unloading of the bobbin - Width 500 mm
- 2 Wrapping cycles
- Number of revolutions at the top and bottom of the pallet adjustable

- **Wrapping capacity:** the machine can wrap from **20 to 500 pallets per day**

- Polymerized epoxy polyester **coating**, **80 to 100 microns with anti-corrosion pre-treatment**
- **Colours:** anthracite grey RAL 7016, **IP level of protection:** IP54



HOW TO USE:

- Loading the pallet under the stretch wrapper
- Start the cycle from the control panel located outside the mesh panels
- Wrapping proceeds in accordance with the settings.
- End of the cycle: position of the arm back to starting state.
- Manual cut
- Bringing a new pallet

TYPES OF FILM:

Any kind of stretch film from 8 to 23 microns (Width: 50 to 500 mm – bobbin diam. 250 mm – Diameter of the roll core diam. 76 mm)

USE:

Functions		« standard » Programmes	Optional
Cycles	Full cycle (wrapping up and down)	<input checked="" type="checkbox"/>	Laser detector n° 2 at the bottom
	Half – cycle (wrapping up only)	<input checked="" type="checkbox"/>	
Film stretching	Electromagnetic brake	<input checked="" type="checkbox"/>	
Speed of the arm	Adjustable	<input checked="" type="checkbox"/>	
Speed of the carriage	Adjustable	<input checked="" type="checkbox"/>	
Overlaps at the bottom	Adjustable	<input checked="" type="checkbox"/>	
Overlaps at the top	Adjustable	<input checked="" type="checkbox"/>	



Mechanical carriage



Control panel



Foldable machine



Easy relocation

These levels enable wrapping of most types of loads.

Equipment manufactured in France in accordance with the regulation in force (CE)

NON CONTRACTUAL DOCUMENT: *in the light of the ongoing development of our products, we reserve the right to modify and change, at any time, our products, dimensions, texts and drawings. Any reproduction whether in part or in whole, is strictly forbidden without written authorization.*

TECHNOLOGIES ET PROCESS D'EMBALLAGE

32, rue de Charette • 28140 TERMINIERS - FRANCE
Tél : 33 (0)2 37 18 58 13 - Fax : 33 (0)2 37 32 11 34 ou 33 (0)2 37 32 14 22
www.rassinouxa.com - Commercial production : clients@rassinouxa.com
Comptabilité : compta.mf@rassinouxa.com - Qualité : qualite@rassinouxa.com

RASSINOX SAS au capital de 2 130 000 Euros—SIRET 353 267 446 00014—APE 2250B—FR 41 353 267 446 CHARTRES
ATECMAA PACKAGING enseigne commerciale de la société RASSINOX SAS—www.atecmaa-packaging.com



ATECMAA
PACKAGING

CUB-X
ACS AUTO CONTROL SYSTEM

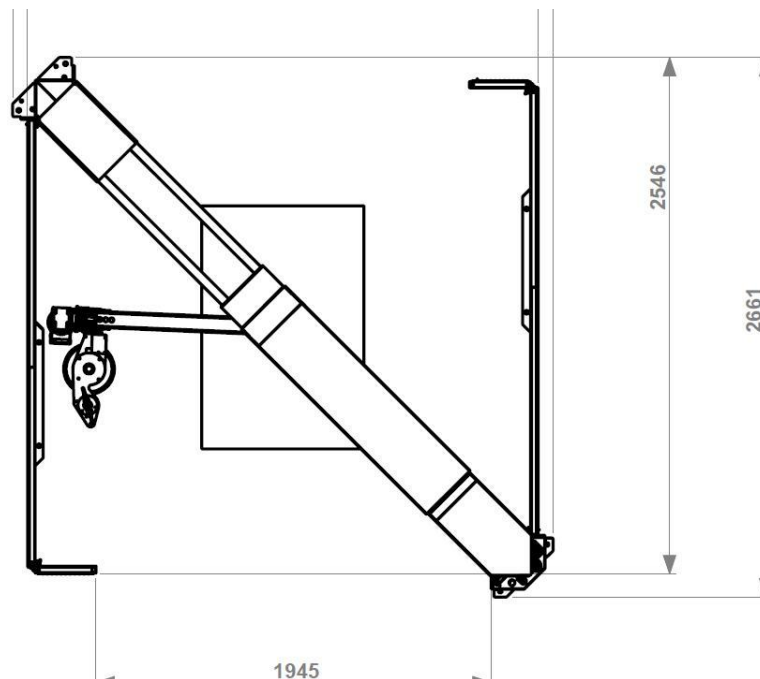
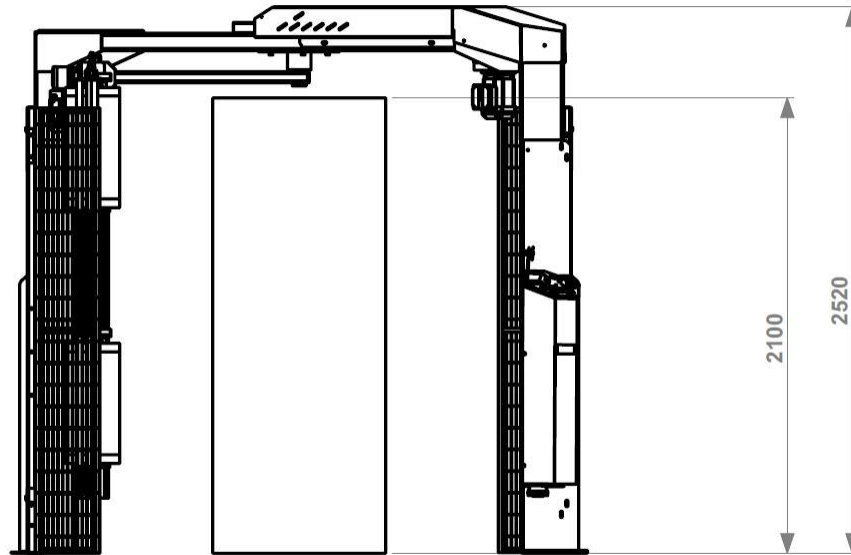

TECHNOLOGIES ET PROCESS D'EMBALLAGE

32, rue de Charette • 28140 TERMINIERS - FRANCE
Tél : 33 (0)2 37 18 58 13 - Fax : 33 (0)2 37 32 11 34 ou 33 (0)2 37 32 14 22
www.rassinouxa.com - Commercial production : clients@rassinouxa.com
Comptabilité : compta.mf@rassinouxa.com - Qualité : qualite@rassinouxa.com

RASSINOX SAS au capital de 2 130 000 Euros—SIRET 353 267 446 00014—APE 2250B—FR 41 353 267 446 CHARTRES
ATECMAA PACKAGING enseigne commerciale de la société RASSINOX SAS—www.atecmaa-packaging.com